



General Instructions for 5.0 Bore Spacing Big Block 5000 Series™ Blocks

WARNING!

PLEASE CHECK THE BLOCK THOROUGHLY IN EVERY POSSIBLE WAY. IF YOU SUSPECT A DEFECT, CONTACT BRODIX, INC. OR THE DEALER IT WAS PURCHASED FROM BEFORE ANY WORK HAS BEGUN. BRODIX® WILL NOT BE RESPONSIBLE FOR VISIBLE DEFECTS AFTER ANY WORK HAS BEEN STARTED.

INSPECT THE BLOCK FOR DAMAGE FROM SHIPPING. INSPECT THE BLOCK OIL PASSAGES AND THREADED HOLES.

WARNING!

THE SLEEVES ARE LEFT ABOVE THE DECK OF THE BLOCK INTENTIONALLY. IT IS THE ENGINE BUILDER'S PREFERENCE WHETHER OR NOT TO SURFACE THE SLEEVES FLAT WITH THE DECK OF THE BLOCK.

ALL PLUGS, LOCKS, AND SCREWS MUST HAVE ANTI-SEIZE ON THE THREADS.

- The sleeves must be clearanced before initial installation of crank and rods.
- The block must be align honed and checked for bearing clearance.
- The cylinders must be finish bored and honed.
- You must check clearance before the final installation of crank, rods, pistons, and cam in the block.
- Wash the block thoroughly with soap and water, and blow dry with air.
- Install the rear cam plug with the o-ring and snap ring in place.
- Install all required water and oil plugs.
- Apply anti-seize to all main and head stud threads before installation. Hand tighten only.
- It is recommended that a 3/8 x 4 1/2 allen head cap screw is used in starter bolt location. This length allows proper thread engagement.

The BRODIX® babbit cam bearing, part number FM 1874, uses three 1/4 inch allen head cap screws to lock the center three bearings in place. The allen head cap screws must be fitted for the proper length. The front and the rear bearing will use spiral locks. Roller bearings are held into place on both sides with spiral locks.

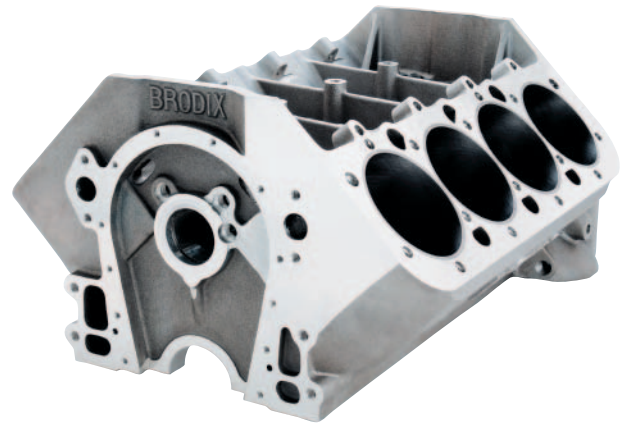

**IF YOU NEED TECHNICAL ASSISTANCE,
CALL (479) 394-1075**

OIL RESTRICTORS
-6 AN (ONLY AVAILABLE FROM BRODIX)

-7 AN PLUG
O-RING

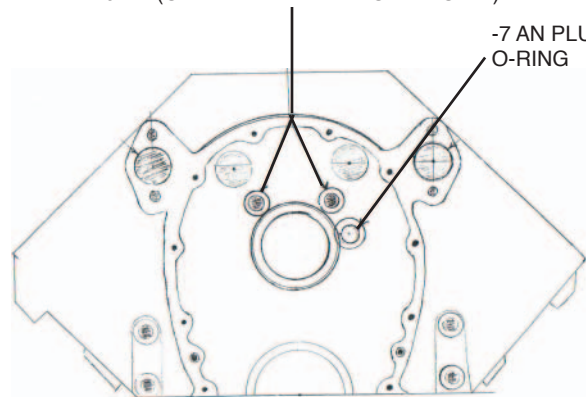

Thank You For Buying BRODIX!

-6 AN PLUG AND O-RING

-7 AN PLUG
O-RING

1 5/16 PLUG
O-RING

1 5/16 PLUG
O-RING

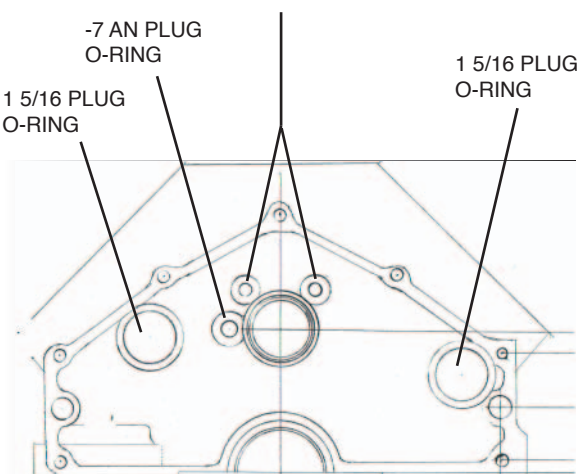

ORDER, TECH, AND INFORMATION: (479) 394-1075 • FAX: (479) 394-1996

www.brodix.com • 301 MAPLE AVENUE • P.O. BOX 1347 • MENA, AR 71953

CAM LOCATION AND SPECS

- 1.0 RAISED CAM
- AVAILABLE WITH ROLLER CAM BEARINGS:
50 mm
- BIG BLOCK FORD ROLLER BEARINGS:
55 mm ROLLER
- AVAILABLE WITH BABBIT BEARINGS:
55 mm BABBIT
60 mm BABBIT
- BIG BLOCK FORD BABBIT

ACCESSORIES

- STARTER BOSS ON RIGHT SIDE
- OIL FILTER LOCATION ON BLOCK
- SPECIAL HEAD STUDS AVAILABLE FROM BRODIX
- PLUG KITS INCLUDED FOR BLOCKS
- INTERNAL HEAD STUD LUG INCLUDED

MAIN CAPS

- BILLET STEEL MAIN CAPS
- 12 PT MAIN STUD NUTS
- ALIGN HONE AVAILABLE

HEIGHTS OF BLOCKS

- 11.200 (8B 5000)
- 11.625 (8B 5025)
- SPECIAL DECK HEIGHTS AVAILABLE

TORQUE SPECS

- OUTSIDE MAIN 85 ft-lb
- INSIDE MAIN 95 ft-lb
- VALLEY LUG BOLTS 50 ft-lb
- TORQUE WITH 30W MOTOR OIL

STROKE CLEARANCE

- 5.375 STANDARD
- 5.750 (WITH ADDITIONAL MACHINING)

SLEEVES

- 4.585 i.d., 4.815 o.d., 7.250 o.a.l. (11.200 DECK)
- 4.585 i.d., 4.815 o.d., 8.000 o.a.l. (11.625 DECK)
- 4.655 i.d., 4.875 o.d., 7.250 o.a.l. (11.200 DECK)
- 4.655 i.d., 4.875 o.d., 8.000 o.a.l. (11.625 DECK)

BLOCK PART NUMBERS

8B 5000

- 4.585 BORE, 1.0 RAISED CAM LOCATION,
11.200 DECK HEIGHT.

8B 5025

- 4.585 BORE, 1.0 RAISED CAM LOCATION,
11.625 DECK HEIGHT.

MUST SPECIFY DECK HEIGHT, CAM BEARING STYLE, LIFTER SIZE, LENGTH OF STROKE, AND CAM LOCATION.

MAIN CAPS

8B MC 454 ST-S-C-GO
8B MC 454 ST-S-C-PF
8B MC 454 ST-S-F-GO
8B MC 454 ST-S-F-PF
8B MC 454 ST-S-R-GO
8B MC 454 ST-S-R-PF

MAIN STUDS AND NUTS

8B MS4050 1/2
8B MS4250 1/2
8B MS4650 1/2

SLEEVES

8B SL 45-330: 4.585 i.d., 4.815 o.d., 8.000 o.a.l.
8B SL 45-335: 4.585 i.d., 4.815 o.d., 7.250 o.a.l.
8B SL 45-340: 4.655 i.d., 4.875 o.d., 7.250 o.a.l.
8B SL 45-345: 4.655 i.d., 4.875 o.d., 8.000 o.a.l.

OTHER SIZES AVAILABLE,
CALL FOR DIMENSIONS AND PART NUMBERS

HEAD STUDS

SK HS PB 5000 FOR
BRODIX HEADS

DOWELS

CALL BRODIX FOR PART
NUMBERS

CAM BEARINGS

8B CAM BEARING ROLLER
CAM 50 mm
8B CAM BEARINGS 60 mm
BABBIT
8B CAM BEARINGS 55 mm
(ROLLER)
8B CAM BEARINGS FORD
ROLLER
55 mm BABBIT -
(SPECIAL ORDER)
8B CAM BEARING 60 mm
BABBIT

PLUGS AND O-RINGS

8B ORING BLOCK PLUG
8B PLUG 814-6C
8B PLUG 814-7C
8B ORING/RCAM PLUG BB
8B ORING/RCAM PLUG 55

CAM PLUGS

8B RCAM PLUG 55
8B RCAM PLUG BB
8B RCAM BB RING
8B SPIRAL LOCK BB
8B SPIRAL LOCK 55
8B RCAM PLUG FORD

OIL RESTRICTORS

8B BB OIL RESTRICTORS
(CUSTOM FOR BRODIX
BLOCK)

WARRANTY DISCLAIMER

No warranties of any nature (expressed, implied, fitness of usage or merchantability) are given on these products. Seller undertakes no responsibility for any product sold. Additional disclaimers are within and are binding upon this contract. Due to the intended usage of products offered, all products are sold on an "as-is" basis, and no warranties of any kind, whether written or oral are made by BRODIX, Inc., its agents or employees. All implied warranties, including the implied warranties of merchantability and fitness are expressly excluded, and the buyer bears the entire risk as to quality performance and use of these products. BRODIX, Inc. will assume no responsibility of personal injury, labor or other injury arising out of the usage of high performance racing parts or products. Any defective part will be handled between the original manufacturer and the buyer. BRODIX, Inc. reserves the right to change specifications, prices and discontinue parts without notice. Installation of BRODIX heads may adversely affect the vehicle manufacturer's warranties, and may violate State and Federal laws when vehicles so equipped are operated other than strictly off-highway. BRODIX reserves the right to discontinue any product at its sole discretion and without any liability with respect to similar products already in the field. Some parts are not legal for sale or use on pollution controlled motor vehicles.

WHILE OUR PRODUCTS ARE USED ON MANY SUPER-CHARGED APPLICATIONS SUCCESSFULLY, PLEASE BE AWARE THAT THERE IS A GREATER POTENTIAL FOR ENGINE DAMAGE DUE TO THE POSSIBILITY OF TUNING ERRORS.

PRICES ARE SUBJECT TO CHANGE WITHOUT NOTICE. ALWAYS CONFIRM PRICE WHEN PLACING YOUR ORDER. WE WILL MAKE EVERY EFFORT TO KEEP YOU INFORMED OF INCREASES.

ORDER, TECH, AND INFORMATION: (479) 394-1075 • FAX: (479) 394-1996
www.brodix.com • 301 MAPLE AVENUE • P.O. BOX 1347 • MENA, AR 71953

Not legal for sale or use on pollution controlled motor vehicles.

© Copyright 2010 Brodix, Inc.